

HELICOFLEX®
SPRING-ENERGIZED METAL SEALS
WORLD CLASS SEALING TECHNOLOGY

Technetics
GROUP
EnPro Industries companies

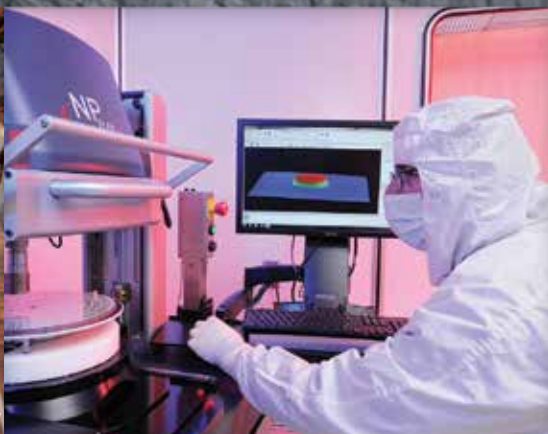

Source: Credit © CERN

Introducing the HELICOFLEX® Seal

The HELICOFLEX® seal has been created with the technical collaboration of the French Atomic Energy Commission (CEA). It is an elastic metallic seal which results from a long experimentation and which has proved its efficiency in many fields from research to industry. Its basic concept (sealing lining + spring) allows, through the technical knowledge of Cefilac, to adjust the characteristics and the shapes of the seal to your assembly and to meet the sealing requirements.

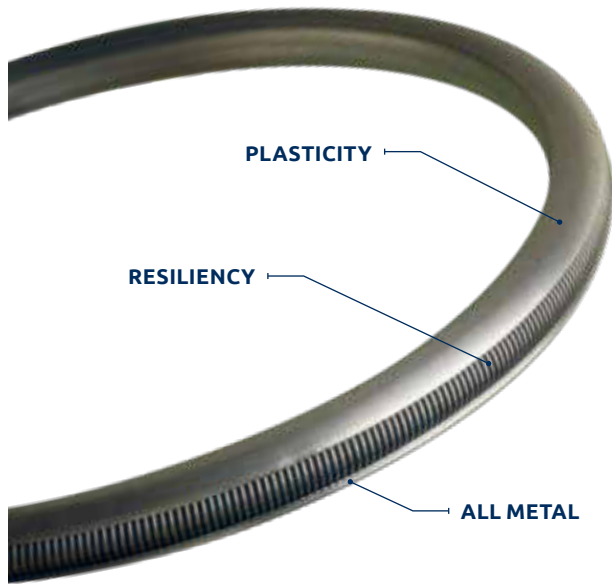

HELICOFLEX® SEALING CONCEPT

The sealing concept of the HELICOFLEX® seal is based on **viscoplastic deformation** of a metallic lining. This lining is selected based on its plasticity, which has to be better than the flange material plasticity. Such deformation is obtained by compressing a helicoidal spring. The spring gives to the HELICOFLEX® seal its remarkable **elasticity**.

The use of a helicoidal spring with joined coils as the elastic core ensures an outstanding level of adaptability to flange geometry and defects.

THE CHOICE OF THE SPRING CHARACTERISTICS ALLOWS:

- To adjust compression load based on type of lining material and required sealing level.
- To control the load needed to ensure a permanent contact between the flanges.

GENERAL CHARACTERISTICS

- DN 4 to 8000 mm
- Ø 1,5 to 40 mm cross section
- Sealing level from bubble tightness down to 10^{-12} Pa.m³.s⁻¹
- Temperature from -272° up to 800°C
- Pressure from 10^{-10} mbar up to 3000 bar
- Very good resistance to radiation
- Very good resistance to corrosion
- Extended life time
- Adaptable to all types of sealing surfaces (FF, RF, TG, Groove,....) (3 faces, radial, shaped,...)
- Adaptable to all flange standards (PNEUROP, ANSI, ISO,...)

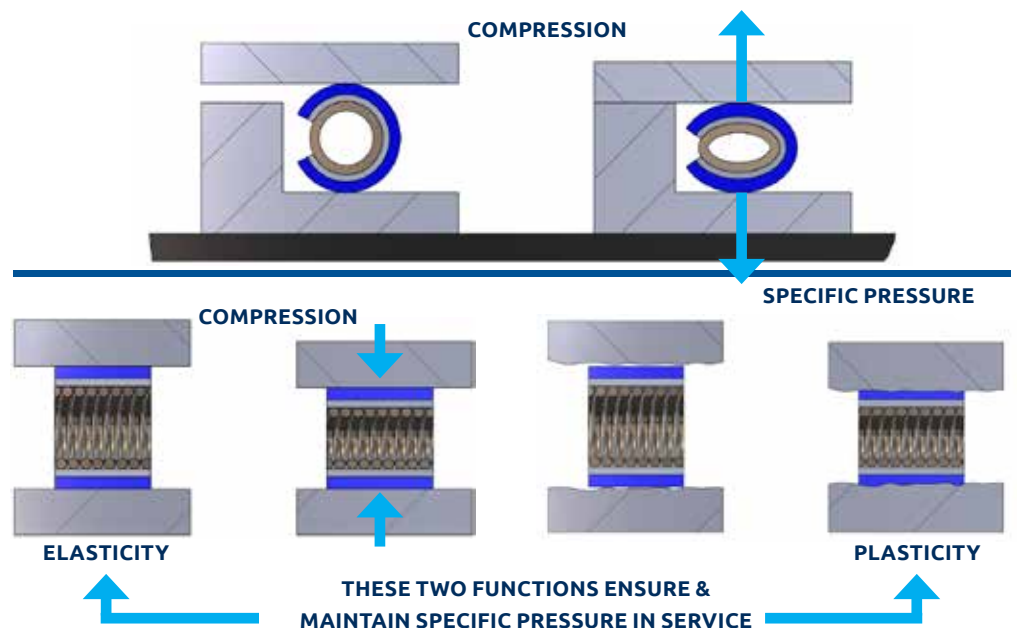

Metal to Metal Assembly

The metal to metal assembly consists in generating a solid mechanical contact independent of the active part of the seal. The seal elasticity is exclusively dedicated to maintaining the sealing. This concept protects the seal from over tightening.

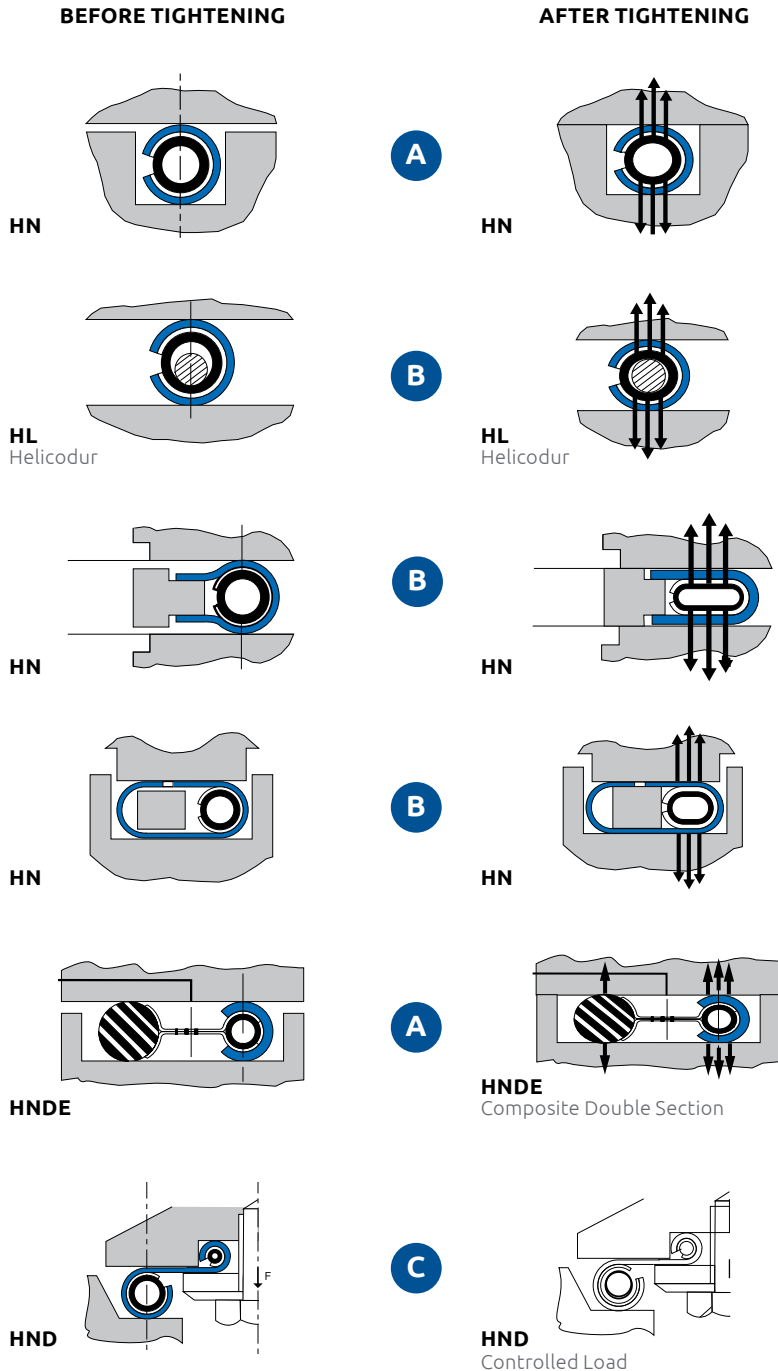

CONTROL OF THE COMPRESSION

The HELICOFLEX® seal requires, in case of a static sealing application, controlled compression either by means of a groove **A** or by means of a built-in compression limiter **B**. In case of a semi-static application, it requires a controlled seating load **C**.

ADVANTAGES OF THE METAL/METAL CONTACT

- Optimized compression
- Minimum elastic deformation required
- Rigid assembly
- Excellent withstanding to thermal transients

BEFORE TIGHTENING

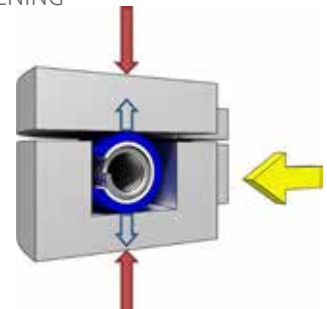

AFTER TIGHTENING

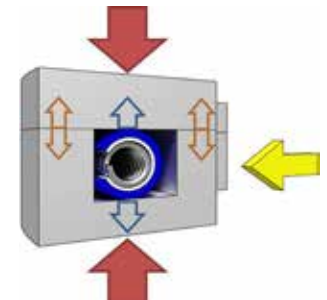

Advanced Sealing for Critical Applications

BASIC VERSION

Standard circular
Cross Section (C.S.)

**HELICOFLEX®
HN**

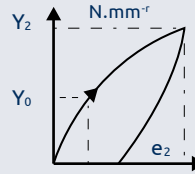
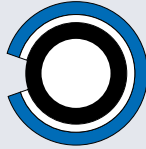

USED IN MOST CASES WITH:

- single or double lining
- single or double C.S.

In the various types or shapes mentioned in pages 7 to 16

ADAPTABILITY BY THE SEAL GEOMETRY

<p>HLO</p>			<p>The seal section is oval and allows its use in trapezoidal grooves in place of RTJ gaskets</p>	<p>HNR</p>		<p>The grinding of the spring according to an angle β perfectly gives the possibility to modulate the seal tightness</p> <p>Wire Section </p>
<p>HL</p>			<p>Has an internal limiter to control the compression Used in a non metal to metal assembly Accepts a retightening</p>	<p>HNV</p>		<p>Particular shape of the seal resulting in a lower point for initial sealing level Y_0 as well as for sealing point Y_2</p>

ADAPTABILITY BY THE DESIGN FLEXIBILITY

<p>GROOVE</p>	<p>TONGUE & GROOVE</p>	<p>RAISED FACE</p>	<p>RADIAL</p>	
<p>CONICAL FLANGE</p>	<p>3 FACES CONTACT</p>	<p>PUPPET VALVE</p>	<p>BUTTERFLY VALVE</p>	<p>LEAK CHECK</p>

ADAPTABILITY BY THE MATERIAL CHOICE

Sealing lining: Aluminum - Gold - Silver - Iron - Copper - Brass - Soft Steel - Nickel - Monel - Tantalum
Stainless Steel (304L - 316L - 321 - 316 Ti) - Zirconium - Inconel (600 - 625) - Hastelloy - Titanium - Tin

Special materials on demand

Coatings: Gold - Silver - Tin - Nickel - FEP

Spring: Nimonic 90 - Alloy 718 - Alloy 750 - SS - XC80

ADAPTABILITY TO THE APPLICATION

Also for: Pneurop flanges, for conical flanges, for remote handling, for valves.



- HELICOFLEX®/RUBBER SECTION
- DOUBLE HELICOFLEX® SECTION
- SEAL WITH SPACER
- SEAL WITH LEAK CHECK

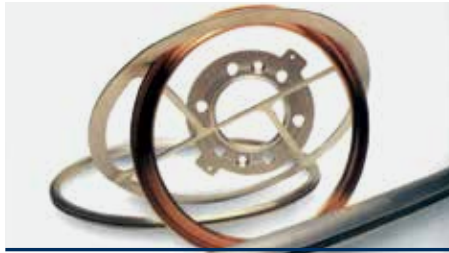

- VERY LARGE SEAL
- SEAL WITH RIB
- SEAL WITH CLIP



- SHAPED SEAL, RACE TRACK, OBLONG, SQUARE, WITH PTFE COATING

Demanding Environments



RESEARCH



AEROSPACE



NEW NUCLEAR REACTOR



NUCLEAR (NPP)



CRYOGENICS



CHEMICAL/PETROCHEMICAL



NUCLEAR (FUEL CYCLE)



AUTOMOTIVE



SEMICONDUCTOR

Design Considerations

SEALING CRITERIA

The characteristic values given in this catalog are designed to meet 2 distinct sealing criteria.

The choice of sealing criteria according to the different assembly requirements (gas sealing, liquid sealing, toxicity, pollution,...) must be done before designing the assembly due to the consequences.

- The “bubble tight” sealing corresponding to a gaseous flow of air $\leq 10^{-5} \text{ Pa.m}^3.\text{s}^{-1}$ ($10^{-4} \text{ atm.cm}^3.\text{sec}^{-1}$) under 1 bar ΔP .
- The Helium sealing corresponding to a gaseous flow of Helium $\leq 10^{-10} \text{ Pa.m}^3.\text{s}^{-1}$ ($10^{-9} \text{ atm.cm}^3.\text{sec}^{-1}$) under 1 bar ΔP . Some lower gas flow ($10^{-12} \text{ Pa.m}^3.\text{s}^{-1}$) can be achieved according to the choice of the lining, but that requires a super polishing of seal and sealing surfaces.

SURFACE FINISH

The sealing level of the HELICOFLEX® seal is directly and closely related to the quality of the surface finish of the sealing areas. The sealing surface finish is critical from both roughness and method of machining standpoints. Lathe finishes have to be recommended for circular seals ; milling should be avoided. The below table summarizes these recommendations.

• Circular seals for use on turned surface

N° LCA - CEA	N10	N9	N8	N7	N6	N5	N4
Ra in μm	12,5	6,3	3,2	1,6	0,8	0,4	0,2
Rt in μm	50	37	21	11	6,2	3,4	1,9
μ . inches	500	250	125	63	32	16	8
Plating (Pb, Sn, In) PTFE - FEP	⚠	⚠	⚠	●	●	●	●
Aluminum	●	●	●	●	●	●	●
Silver, copper, iron	⚠	●	●	●	●	●	⚠
Nickel, stainless steel	⚠	●	●	●	●	●	●

⚠ not recommended (please consult us) ● correct values acceptable ● correct values recommended

Note: The sealing areas must be turned by lathe. It is not recommended to try to get the required roughness by polishing with abrasive paper. This process must be reserved for refurbishing damaged sealing surface. This polishing has to be done in the same circular way as machining by lathe.

SHAPE SEALS (RECTANGULAR, OBLONG, ...) FOR USE ON MACHINED SURFACE

The surfaces, using shape seals, are obtained with processes less favorable to the sealing performance than lathe machining. By consequence, the seal requires a design, compared to the circular seal, with a stiffer spring. For non circular seals, the sealing surface finish has to be better whatever the lining ($Ra = 0,4 \text{ à } 0,8 \mu\text{m}$). In case the roughness can not be obtained, a specific tool generating preferential polishing lines can be recommended.

Dimensions	Amplitude*	Tangential*	Radial* slope
DN 10 to 500	0,2 mm	0,1/100	1/100
DN 500 to 2000	0,4 mm	0,2/100	2/100
DN 2000 to 5000	0,8 mm	0,5/100	3/100

* Average value to adjust according to the cross section.

FLATNESS TOLERANCE

Thanks to its spring concept, the HELICOFLEX® seal accepts flatness defects. The following flatness tolerances can be acceptable on the flange assembly (cumulated value for both flanges). A local defect could generate a lack of compression that shall not exceed 20% of the nominal value.

Characteristic Values

LOAD VERSUS DEFLECTION CURVE

The compression and decompression cycle of the HELICOFLEX® seal shows a progressive flattening of the curve. The position of this step is selected according to the required sealing and the lining material.

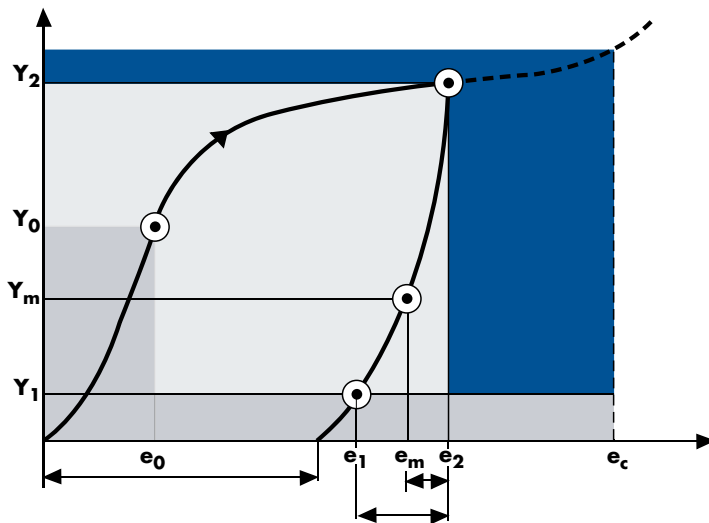

- Y₀** = Linear load from where the required sealing level is obtained.
- Y₂** = Linear load to reach the seating point and the metal to metal contact.
- e₂** = Compression value to get the metal to metal contact. It is related to the linear load **Y₂** and determines the groove depth.
- e_c** = Critical compression value beyond which the sealing level could deteriorate.
- Y_m** = Minimum linear load to maintain sealing in service. It varies according to the pressure and the temperature.
- e_m** = Compression values related to **Y_m** below which the sealing level is lost.
- (l)** = Function of **P & T**.

PRESSURE/TEMPERATURE CHART

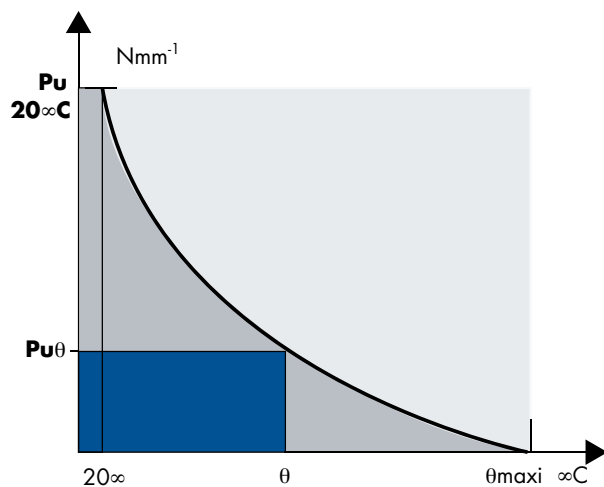

- P_u** = Maximum pressure: it is the maximum pressure that the seal can withstand at a certain temperature.
- P_{u 20°C}** = Maximum pressure at room temperature (20°C)
- P_{u theta}** = Maximum pressure at service temperature.
- theta maxi** = This value allows the **Y_m** calculation. Temperature where **P_{u theta}** is close to zero.

VALUES TO TAKE INTO ACCOUNT FOR THE HELICOFLEX® CALCULATION (PAGE 12)

Refer to tables, page 7, for standard seals and page 15 for HELICOFLEX® delta HNV. Consult us for all other specific seals (HELICOFLEX® beta HNR, shape seals, Omicron,...) The **Y₂**, **e₂**, **e_c**, **Y₁** values are directly readable in the tables.

For $\Theta_1 < \Theta < \Theta_2$, **P_{u theta 1}** and **P_{u theta 2}** allow to linearly interpolate **P_{u theta}** with a safety margin. **Y_m** is calculated with **P**, **P_{u theta}**, **Y₁**, **Y₂** (see page 12).

Table of Characteristic Values

(standard HN, axial compression)

LINING: ALUMINUM GOLD

C.S. mm	COMPRESSION		RECOMMENDED SURFACE FINISH				BUBBLE SEALING				T°C maxi	RECOMMENDED SURFACE FINISH
	e ₂ mm	e _c mm	Y ₂ N.mm ⁻¹	Y ₁ N.mm ⁻¹	Pu20° MPa	Pu@ 200° MPa	Y ₂ N.mm ⁻¹	Y ₁ N.mm ⁻¹	Pu 20° MPa	Pu@ 200° MPa	°C	
1,6 (1,6 à 1,8)	0,6 ± 0,05	0,7	150	20	50	-	90	20	35	-	150	1,6 to 3,2 µm
2 (1,9 à 2,1)	0,7 ± 0,1	0,85	160	20	52	-	100	20	40	-	150	
2,2 (2,2 à 2,4)	0,7 ± 0,1	0,9	165	20	53	-	105	20	40	-	180	
2,6 (2,5 à 2,9)	0,7 ± 0,1	0,9	175	20	55	5	115	20	42	5	220	
3 (3 à 3,4)	0,8 ± 0,1	1	185	25	55	10	130	20	45	10	250	
3,5 (3,5 à 3,9)	0,8 ± 0,1	1	190	25	55	14	140	20	47	14	250	
4 (4 à 4,4)	0,9 ± 0,1	1,1	200	25	60	17	150	20	50	17	280	
4,5 (4,5 à 4,9)	0,9 ± 0,1	1,2	210	25	60	20	160	20	52	20	280	
5,1 (5 à 5,4)	0,9 ± 0,1	1,4	220	30	63	22	170	25	55	22	300	
5,6 (5,5 à 5,9)	0,9 ± 0,1	1,6	230	30	65	24	180	25	57	24	320	
6,6 (6 à 6,9)	1 ± 0,1	1,8	245	35	67	25	195	30	60	25	340	
7,6 (7 à 7,9)	1 ± 0,1	2,2	270	40	70	28	205	35	65	28	340	
8,6 (8 à 8,9)	1 ± 0,1	2,6	290	50	72	32	225	40	68	31	360	
9,8 (9 à 9,9)	1 ± 0,1	3	325	55	75	33	235	50	72	32	380	
10,8 (10 à 10,9)	1,1 ± 0,1	3,5	350	60	75	36	245	50	73	33	380	
11,8 (11 à 12,9)	1,1 ± 0,1	3,8	375	70	80	38	255	60	77	35	400	
14,2 (13 à 14,9)	1,2 ± 0,15	4,6	400	80	82	40	295	65	80	36	400	
16,2 (15 à 16,9)	1,3 ± 0,15	5,4	465	90	84	42	345	75	82	38	430	
18,2 (17 à 18,9)	1,5 ± 0,15	6,2	540	110	85	43	400	90	82	39	430	
19 à 25	2 ± 0,2	7	725	130	90	45	550	100	85	40	450	
26 à 30	2,8 ± 0,25	9	925	190	90	45	700	150	85	40	450	
31 à 40	3,5 ± 0,3	12	1160	250	90	45	900	200	85	40	450	

LINING: SILVER

C.S. mm	COMPRESSION		RECOMMENDED SURFACE FINISH				BUBBLE SEALING				T°C maxi	RECOMMENDED SURFACE FINISH
	e ₂ mm	e _c mm	Y ₂ N.mm ⁻¹	Y ₁ N.mm ⁻¹	Pu20° MPa	PuΘ 250° MPa	Y ₂ N.mm ⁻¹	Y ₁ N.mm ⁻¹	Pu 20° MPa	PuΘ 250° MPa	°C	
1,6 (1,6 à 1,8)	0,5 ± 0,05	0,6	200	30	65	-	150	30	40	-	240	1,6 to 3,2 µm
2 (1,9 à 2,1)	0,6 ± 0,05	0,7	220	30	65	-	150	30	40	-	240	
2,2 (2,2 à 2,4)	0,6 ± 0,05	0,8	230	35	70	6	160	30	40	4	280	
2,6 (2,5 à 2,9)	0,7 ± 0,1	0,9	240	45	75	8	170	40	45	5	280	
3,1 (3 à 3,4)	0,8 ± 0,1	1	260	50	85	14	180	45	50	9	300	
3,6 (3,5 à 3,9)	0,8 ± 0,1	1	280	50	95	22	190	45	55	13	300	
4,2 (4 à 4,4)	0,8 ± 0,1	1,1	300	55	105	27	200	45	60	16	350	
4,7 (4,5 à 4,9)	0,8 ± 0,1	1,1	320	60	115	31	220	50	70	19	370	
5,2 (5 à 5,4)	0,8 ± 0,1	1,3	340	60	125	36	230	50	80	22	370	
5,7 (5,5 à 5,9)	0,8 ± 0,1	1,4	360	65	135	40	250	50	90	25	400	
6,2 (6 à 6,9)	0,9 ± 0,1	1,7	400	70	150	47	270	60	110	30	450	
7,2 (7 à 7,9)	0,9 ± 0,1	2	440	80	160	54	300	65	125	36	450	
8,4 (8 à 8,9)	0,9 ± 0,1	2,4	490	90	170	60	350	70	140	42	500	
9,4 (9 à 9,9)	0,9 ± 0,1	2,7	540	100	180	67	390	80	150	48	500	
10,8 (10 à 10,9)	1 ± 0,1	3,1	600	110	185	73	440	90	155	54	500	
11,8 (11 à 12,9)	1 ± 0,1	3,4	640	130	185	81	520	100	155	60	550	
12,95 (12,95 à 14,9)	1,2 ± 0,15	4,2	680	150	185	88	580	120	155	67	550	
15,8 (15 à 16,9)	1,3 ± 0,15	5	1100	200	190	95	740	140	155	71	550	
17,8 (17 à 18,9)	1,5 ± 0,15	5,8	-	-	-	-	860	170	155	73	550	

Table of Characteristic Values (Continued)

(standard HN, axial compression)

LINING: COPPER, SOFT IRON, MILD STEEL

C.S. mm	COMPRESSION		RECOMMENDED SURFACE FINISH				BUBBLE SEALING				T°C maxi	RECOMMENDED SURFACE FINISH
	e _z mm	e _c mm	Y ₂ N.mm ⁻¹	Y ₁ N.mm ⁻¹	Pu20° MPa	PuØ 300° MPa	Y ₂ N.mm ⁻¹	Y ₁ N.mm ⁻¹	Pu 20° MPa	PuØ 300° MPa	°C	
1,7 (1,6 à 1,8)	0,5±0,05	0,6	260	40	50	10	190	30	35	5	350	1,6 to 3,2 µm
1,9 (1,9 à 2,1)	0,6±0,5	0,7	280	50	50	11	200	40	35	6	350	
2,34 (2,2 à 2,4)	0,6±0,5	0,8	300	60	55	13	220	50	35	8	360	
2,74 (2,5 à 2,9)	0,7±0,1	0,9	320	70	60	17	230	60	40	10	380	
3,24 (3 à 3,4)	0,7±0,1	1	350	80	65	20	250	70	40	12	380	
3,84 (3,5 à 3,9)	0,7±0,1	1	390	80	70	23	270	70	45	15	400	
4,34 (4 à 4,4)	0,8±0,1	1,1	430	90	70	27	290	80	45	17	420	
4,84 (4,5 à 4,9)	0,8±0,1	1,1	470	100	80	30	320	80	45	19	450	
5,34 (5 à 5,4)	0,8±0,1	1,3	510	110	85	33	330	90	50	21	450	
5,84 (5,5 à 5,9)	0,8±0,1	1,4	550	120	90	36	360	100	50	23	480	
6,34 (6 à 6,9)	0,9±0,1	1,7	630	140	95	40	420	100	55	26	520	
7,54 (7 à 7,9)	0,9±0,1	2	740	160	100	45	460	110	60	29	520	
8,54 (8 à 8,9)	0,9±0,1	2,4	860	190	110	49	530	130	65	32	550	
9,94 (9 à 9,9)	0,9±0,1	2,7	990	220	150	52	600	140	70	35	580	
10,94 (10 à 10,9)	1±0,1	3,1	-	-	-	-	670	160	75	37	580	

LINING: NICKEL, MONEL, TANTALUM

C.S. mm	COMPRESSION		RECOMMENDED SURFACE FINISH				BUBBLE SEALING				T°C maxi	RECOMMENDED SURFACE FINISH
	e ₂ mm	e _c mm	Y ₂ N.mm ⁻¹	Y ₁ N.mm ⁻¹	Pu20° MPa	PuØ 350° MPa	Y ₂ N.mm ⁻¹	Y ₁ N.mm ⁻¹	Pu 20° MPa	PuØ 350° MPa	°C	
1,6 (1,6 à 1,8)	0,4 ± 0,05	0,5	320	80	70	11	200	60	40	7	380	0,8 to 1,6 µm
2 (1,9 à 2,1)	0,5 ± 0,05	0,6	350	80	72	16	220	60	42	9	380	
2,4 (2,2 à 2,4)	0,5 ± 0,05	0,7	390	90	76	21	230	70	44	12	420	
2,6 (2,5 à 2,9)	0,6 ± 0,05	0,8	450	100	82	27	270	70	47	16	450	
3,2 (3 à 3,4)	0,6 ± 0,05	0,9	440	110	87	34	300	80	50	20	480	
3,7 (3,5 à 3,9)	0,6 ± 0,05	0,9	580	120	93	40	340	90	54	23	500	
4,2 (4 à 4,4)	0,7 ± 0,1	1	640	140	96	45	380	100	57	27	550	
4,7 (4,5 à 4,9)	0,7 ± 0,1	1	700	150	105	52	420	110	60	30	600	
5,2 (5 à 5,4)	0,7 ± 0,1	1,1	780	180	110	57	460	110	65	33	650	
5,9 (5,5 à 5,9)	0,7 ± 0,1	1,3	850	200	115	62	500	120	67	37	650	
6,4 (6 à 6,9)	0,8 ± 0,1	1,6	-	-	-	-	560	130	72	41	650	
7,4 (7 à 7,9)	0,8 ± 0,1	1,8	-	-	-	-	650	150	78	45	650	
8,4 (8 à 8,9)	0,8 ± 0,1	2,1	-	-	-	-	730	160	83	50	650	
9,8 (9 à 9,9)	0,8 ± 0,1	2,4	-	-	-	-	820	170	87	53	650	
10,94 (10 à 10,9)	0,9 ± 0,1	2,7	-	-	-	-	920	200	90	56	650	

Table of Characteristic Values (Continued)

(standard HN, axial compression)

LINING: STAINLESS, INCONEL, TITANIUM, ZIRCONIUM

C.S. mm	COMPRESSION		RECOMMENDED SURFACE FINISH				BUBBLE SEALING				T°C maxi	RECOMMENDED SURFACE FINISH
	e ₂ mm	e _c mm	Y ₂ N.mm ⁻¹	Y ₁ N.mm ⁻¹	Pu20° MPa	PuØ 400° MPa	Y ₂ N.mm ⁻¹	Y ₁ N.mm ⁻¹	Pu 20° MPa	PuØ 400° MPa	°C	
1,6 (1,6 à 1,8)	0,4 ± 0,05	0,7	350	100	90	25	300	80	47	6	420	0,8 to 1,6 µm
2 (1,9 à 2,1)	0,5 ± 0,05	0,85	400	100	91	27	320	80	50	8	420	
2,4 (2,2 à 2,4)	0,5 ± 0,05	0,9	450	110	92	29	350	90	52	11	480	
2,6 (2,5 à 2,9)	0,6 ± 0,05	0,9	500	120	97	32	380	100	57	15	500	
3,2 (3 à 3,4)	0,6 ± 0,05	1	575	130	100	36	425	110	62	20	500	
3,7 (3,5 à 3,9)	0,6 ± 0,05	1	660	150	104	39	470	130	67	25	550	
4,2 (4 à 4,4)	0,7 ± 0,1	1,1	750	170	107	42	520	150	72	30	600	
4,7 (4,5 à 4,9)	0,7 ± 0,1	1,2	825	220	110	45	560	180	77	34	650	
5,2 (5 à 5,4)	0,7 ± 0,1	1,4	-	-	-	-	600	190	82	37	700	
5,9 (5,5 à 5,9)	0,7 ± 0,1	1,6	-	-	-	-	650	200	87	42	700	
6,4 (6 à 6,9)	0,8 ± 0,1	1,8	-	-	-	-	720	220	94	47	700	
7,4 (7 à 7,9)	0,8 ± 0,1	2,2	-	-	-	-	800	260	102	52	700	
8,4 (8 à 8,9)	0,8 ± 0,1	2,6	-	-	-	-	900	290	108	58	700	
9,8 (9 à 9,9)	0,8 ± 0,1	3	-	-	-	-	1000	340	115	62	700	
10,6 (10 à 10,9)	0,9 ± 0,1	3,5	-	-	-	-	1070	370	120	66	700	

Please consult us for the material not listed, the coated seals (Gold, Silver, Tin, Nickel, FEP).

- For the HELICOFLEX® beta HNR see [page 16](#).
- For HELICOFLEX® delta HNV, see [page 15](#).
- For radial or 3 faces compression, see [page 14](#).

Calculation Data for HELICOFLEX® Seal

The tightening load for a HELICOFLEX® seal can be calculated according to the CODAP (Annexe C6A4) or by analogy with the calculation done for the flat gaskets.

WE CAN SUPPLY CALCULATION DATA SHEET ACCORDING TO THE FOLLOWING PROCESS:

PARAMETERS	FORMULA	UNITS
D_j	Mean diameter of the seal	N
Y₂	Linear seating load of the seal	N
Y₁	Threshold of sealing lost at 20°C/1bar	N.mm ⁻¹
P	Calculation pressure (working, design or test)	N
Et_{20°}	Young modulus of the bolt material at 20°C	N
E_{ts}	Young modulus of the bolt material at calculation temperature	N
Pu	Max pressure at 20°C	N
Puθ	Max pressure at design P & T	N

CALCULATION OF THE MINIMUM TIGHTENING LOAD	FORMULA	UNITS	
F_j	Seating load of the seal	$= \pi \times Dj \times Y_2 \times 1.1$	N
F_f	Hydrostatic force from the pressure	$= \pi/4 \times Dj^2 \times P$	N
Y_m	Minimum linear load to keep the sealing	$= \text{Max} (Y_1 ; Y_2 \times P/Pu\theta)$	N.mm ⁻¹
F_m	Minimum load to keep the sealing	$= \pi \times Dj \times Y_m$	N
F_s	Total load to insure the sealing	$= F_f + F_m$	N
F_{s*}	Total load taking into account the young modulus compensation	$= F_s \times Et_{20°} / E_{ts}^*$	N
F_{B1}	F _{B1} is the minimum load to be applied on the assembly in order to reach the target leak rate	$= \text{Max} (F_j ; F_{s}^*)$	N
F_{B2}	Min. load for metal-to-metal contact		N
$F_{B2} = k \cdot \text{max}\{F_{s}^*, F_j\}$ with $F_s = F_f + F_j \Rightarrow F_{B2} = k \cdot (F_f + F_j) \cdot E / E_T$ The tightening load F _{B2} ensures the metal-to-metal contact (flange to flange) in operating condition. The load above is not the only parameter to take into account to design the assembly. For instance, the calculations do not take into account any other external load (e.g. moment on the assembly). For questions, please contact our engineering department.			

CALCULATION OF THE BOLT STRESS	FORMULA	UNITS	
S_B	Resistant section of the bolt	mm ²	
N_b	Number of bolts		
σ_a	Stress in the bolts at room temperature	$= F_B \times N_b / S_B$	MPa
σ_{ts}	Stress in the bolts at calculation temperature	$= \sigma_a \times E_{ts} / E_{t20°}$	MPa

CALCULATION OF THE MINIMUM TIGHTENING LOAD	FORMULA	UNITS	
P	Pitch of the bolt	mm	
d₂	Diameter on thread side	mm	
D_m	Diameter of the contact under the screw head	mm	
μ	Friction coefficient of the screw and the nut		
C_s	Torque value in N.mm	$= F_B / N_b \times (0,16 \times p + \mu \times (0,58 \times d_2 + D_m / 2))$	N.mm
C_s	Torque value in N.m	$= C_{s(N.mm)} / 1000$	N.m

Design Considerations

Dimensions of the seals according to the assembly.

AXIAL COMPRESSION

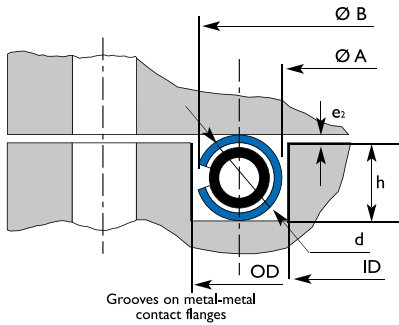

Internal Pressure $P \geq 20$ bars

- Groove assembly : at the end of compression the seal should be in contact with and supported by the groove wall opposed to the pressure side.

$$h = d - e_2$$

Internal pressure:

$$\begin{aligned} \text{Ø B} &= \text{OD} - J \\ \text{Ø A} &\geq \text{ID} + 2e_2 + 0,5 \end{aligned}$$

J	Ø d (C.S.)
0,3	1,5 à 3,4
0,5	3,5 à 6,9
0,7	7 à 9,9
0,9	> 10

J = clearance between seal OD and Groove OD
 $J = f(d)$ (see table)

External Pressure $P \geq 20$ bars

Same concept with internal back up. It is the groove ID which has to contact & support the seal

External or Internal Pressure $P < 20$ bars

The seal can be centered in the groove without radial contact with a minimum groove width
 $w \geq \text{Seal cross section} + 2e_2 + 0,5 \text{ mm.}$

RADIAL COMPRESSION

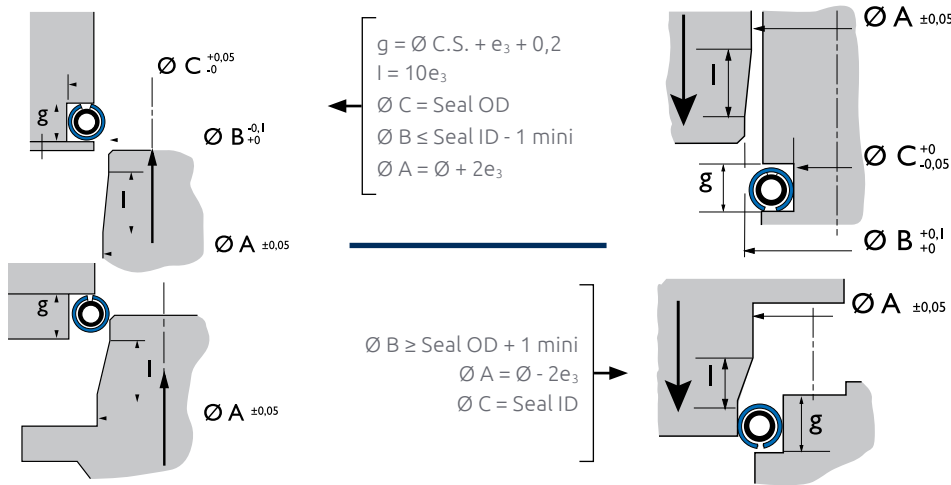

A radial compression is possible with HELICOFLEX® seal by using the adapted types : HN 110, 210, 160, 180. The system offers the option of internal or external compression. The internal compression expands the inner diameter and the external compression restrains the outside diameter.

The main precautions to take concern the material to be used and the roughness of the surface finish of the sealing area which must be smooth ($R_a \leq 0,8 \text{ mm}$) and lubricated during the assembly with a spray (PTFE, graphite, Molybdene, silicone, oil) compatible with the media.

The seal should be maintained in its housing with axial contact. The compression has to be progressive $\leq 0,1 \text{ mm per mm of motion.}$

SILVER			COPPER			NICKEL			STAINLESS STEEL		
Ø mm	e ₃ mm	Y _a N.mm ⁻¹	Ø mm	e ₃ mm	Y _a N.mm ⁻¹	Ø mm	e ₃ mm	Y _a N.mm ⁻¹	Ø mm	e ₃ mm	Y _a N.mm ⁻¹
1,6	0,25	30	1,7	0,20	38	1,6	0,20	40	1,6	0,20	60
2,6	0,30	34	2,34	0,25	44	2,6	0,25	54	2,6	0,25	76
3,1	0,35	36	3,24	0,30	50	3,2	0,30	60	3,2	0,30	84
4,2	0,45	40	4,34	0,40	58	4,2	0,40	76	4,2	0,40	104
5,2	0,45	46	5,34	0,40	66	5,2	0,40	92	5,2	0,40	120
6,2	0,50	54	6,34	0,45	80	6,4	0,45	112	6,4	0,45	144
8,4	0,50	70	8,54	0,45	106	8,4	0,45	146	8,4	0,45	180
10,8	0,60	88	10,94	0,50	134	10,6	0,50	184	10,6	0,50	214

3 FACES OF COMPRESSION

30° Type HN 140 - 240
(150 - 250)

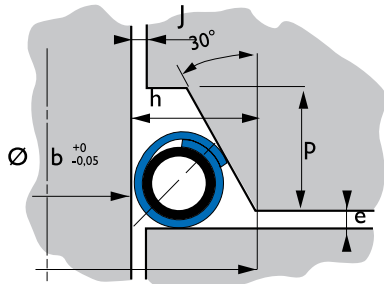

$D = \text{shaft } \varnothing + 2 h$

45° Type HN 140 - 240
(150 - 250)

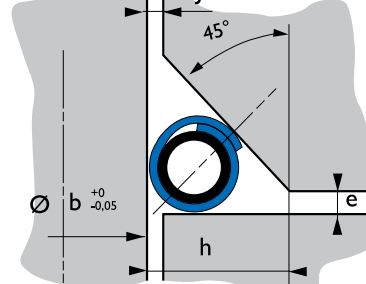

$D = \text{shaft } \varnothing + 2 h$

60° Type HN 100-200
(120-220)

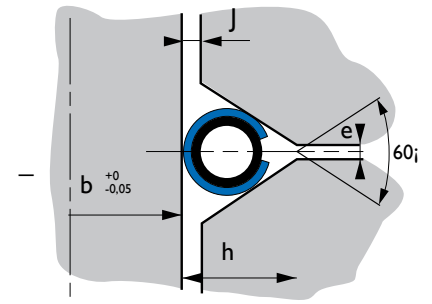

$D = \text{shaft } \varnothing + 2 h$

J&C.S./10

cross section d	h						
	Section D	30°		45°		60°	
		Aluminum	Other Linings	Aluminum	Other Linings	Aluminum	Other Linings
2,6	3,30	3,20	4,15	4,15	3,20	3,40	
3,2	4,00	4,00	5,05	5,05	4,00	4,20	
4,2	5,25	5,25	6,60	6,60	5,40	5,60	
5,2	6,60	6,60	8,30	8,30	6,90	7,10	
6,4	8,15	8,15	10,20	10,20	8,60	8,80	
8,4	10,90	10,90	13,60	13,60	11,60	11,80	
10,6	13,80	13,80	17,25	17,25	14,80	15,00	

Note: These values take into account the lining overlap (30° et 45°)

CHARACTERISTIC VALUES

The axial linear tightening load Y_a and compression value e , can be obtained from Y_2 and e_2 values given page 7, corrected by factors K and a .

Coefficient	30°	45°	60°
a	2	1,4	1,15
k	0,9	1,2	1,4

Axial linear load:

• $Y_0 = K Y_2$

Axial compressive movement:

• $e = a e_2$

HELICOFLEX® Delta - HNV

Patented system CEA - CEFILAC, Licence CEA

CONCEPT OF THE SEALING & APPLICATION FIELDS

- The HELICOFLEX® Δ has 2 knife edges at the contact line of the cross section.
- The height and the shape of these knife edges have been designed so as to disappear during the compression for **ductile linings** (Aluminum, Silver, Copper)
- This aptitude avoids any risk of creep over time or during bake out and thermal cycles
- The **less ductile** linings present very limited risk of creeping and by consequence do not require the disappearing of the knife edge during the compression
- In every case, the exceptional elastic spring back of the HELICOFLEX® Δ can compensate its own creeping and authorize its use at high temperature according to the lining.
- The HELICOFLEX® Δ requires a lower tightening load than the one necessary for metallic seals, **THAT AUTHORIZES ELASTOMER REPLACEMENT** (for example replacement of FKM O. Rings on the ISO/PNEUROP standard flanges).

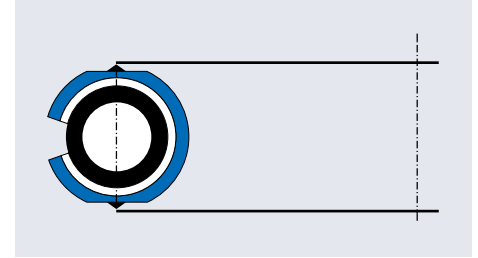

HELICOFLEX® Δ

- Very high sealing performance
- Low tightening load

APPLICATIONS

- Ultra high vacuum
- Space
- Semiconductor

Note:
HELICOFLEX® = HNV
(The V denotes the
Delta type).

HELICOFLEX® Δ

Dimensions: Ø 10 to 2000 mm

Temperature:

- 272° to 520°C (ductile linings).
- 272° to 700°C (less ductile linings).

Sealing level:

$Q \leq 10^{-12} \text{Pa.m}^3.\text{sec}^{-1}$ ($10^{-11} \text{atm.cm}^3.\text{sec}^{-1}$)

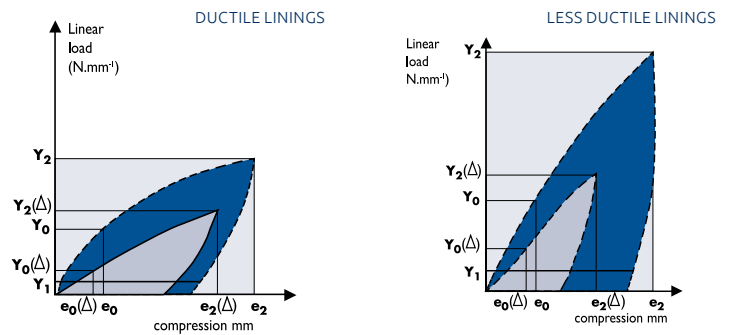

TABLE OF CHARACTERISTIC VALUES: CIRCULAR SEALS (SHAPED SEALS: please consult us)

Ductile Linings - HELICOFLEX® Δ (Delta)

HELIUM SEALING																				
ALUMINUM							SILVER						COPPER							
Ø C.S.		Type	Y ₂ N.mm ⁻¹	e ₂ mm	HV mini	T°C maxi	Ø C.S.		Type	Y ₂ N.mm ⁻¹	e ₂ mm	HV mini	T°C maxi	Ø C.S.		Type	Y ₂ N.mm ⁻¹	e ₂ mm	HV mini	T°C maxi
th mm	on ridges						th mm	on ridges						th mm	on ridges					
2	1,9	HNV 100	100	0,6	65	150	1,8	1,7	HNV 200	150	0,5	100	240	1,7	1,64	HNV 100	150	0,34	110	350
2,7	2,6	HNV 200	140	0,7	65	220	2,5	2,4	HNV 200	160	0,6	100	280	2,44	2,34	HNV 200	180	0,44	120	380
3,4	3,3	HNV 200	140	0,8	65	250	3,2	3,1	HNV 200	160	0,6	100	300	3,14	3,04	HNV 200	180	0,54	120	380
4,9	4,8	HNV 200	140	0,9	65	280	4,8	4,7	HNV 200	160	0,8	100	370	4,64	4,54	HNV 200	180	0,64	120	450
5,8	5,6	HNV 200	150	1	65	320	5,6	5,4	HNV 200	170	0,8	110	400	5,54	5,34	HNV 200	180	0,64	120	480
6,9	6,7	HNV 200	150	1,1	65	340	6,7	6,5	HNV 200	180	0,9	120	450	6,54	6,34	HNV 200	190	0,74	130	520

Less Ductile Linings - HELICOFLEX® Δ (Delta)

HELIUM SEALING																				
NICKEL							STAINLESS STEEL - TANTALUM						INCONEL							
Ø C.S.		Type	Y ₂ N.mm ⁻¹	e ₂ mm	HV mini	T°C maxi	Ø C.S.		Type	Y ₂ N.mm ⁻¹	e ₂ mm	HV mini	T°C maxi	Ø C.S.		Type	Y ₂ N.mm ⁻¹	e ₂ mm	HV mini	T°C maxi
th mm	on ridges						th mm	on ridges						th mm	on ridges					
2	1,9	HNV 100	100	0,6	65	150	1,8	1,7	HNV 200	150	0,5	100	240	1,7	1,64	HNV 100	150	0,34	110	350
2,7	2,6	HNV 200	140	0,7	65	220	2,5	2,4	HNV 200	160	0,6	100	280	2,44	2,34	HNV 200	180	0,44	120	380
3,4	3,3	HNV 200	140	0,8	65	250	3,2	3,1	HNV 200	160	0,6	100	300	3,14	3,04	HNV 200	180	0,54	120	380
4,9	4,8	HNV 200	140	0,9	65	280	4,8	4,7	HNV 200	160	0,8	100	370	4,64	4,54	HNV 200	180	0,64	120	450
5,8	5,6	HNV 200	150	1	65	320	5,6	5,4	HNV 200	170	0,8	110	400	5,54	5,34	HNV 200	180	0,64	120	480
6,9	6,7	HNV 200	150	1,1	65	340	6,7	6,5	HNV 200	180	0,9	120	450	6,54	6,34	HNV 200	190	0,74	130	520

Other Types of HELICOFLEX® Seals

CHARACTERISTIC CURVE

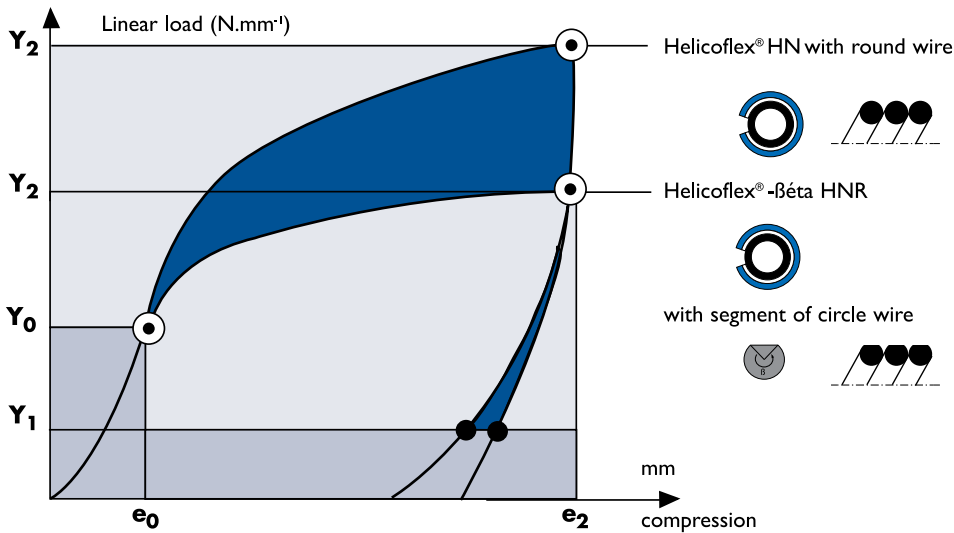

HELICOFLEX® BETA HNR

Sealing principle : the spring of the HELICOFLEX® β is ground all around (see sketch) so as to have a better distribution of the spring reaction on the seal lining.

The load reduction compared to the Y₂ value is theoretically 30 % but we would like to be consulted to design these seals.

Advantages:

- Tightening load reduction for the same sealing level
- Good behaviour in temperature

HELICOFLEX® OMICRON HLO

The Omicron seal is a HELICOFLEX® seal with an internal limiter spacer which is used instead of the RTJ seals. It gets the elastic characteristics of the HELICOFLEX® seal. Due to a different contact point compared to the RTJ seal, it can be used to retrofit damaged flanges.

This seal can be manufactured with soft steel, soft iron, nickel or stainless steel lining.

Performances :

T from -272° to +750°C

P up to 1000 bar.

RTJ

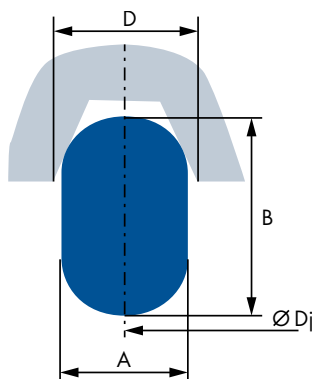



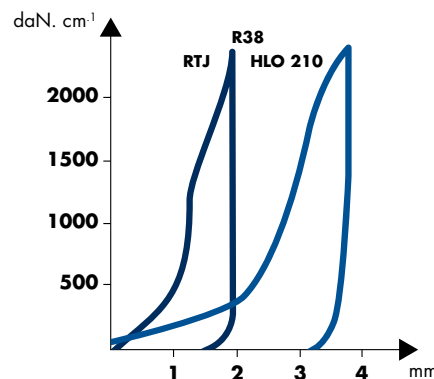

COMPARISON RTJ / HLO 210

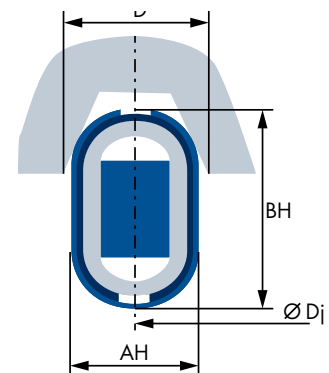

HELICOFLEX® OMICRON HLO 210

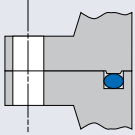

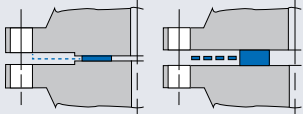
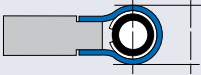
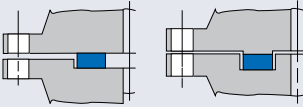
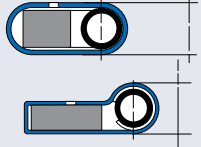
The HELICOFLEX® Seal and the Flange Norms

<p>FLANGES WITH GROOVE</p> 	<p>HN200</p> 	<p>NF 15000 SERIES</p>
<p>RF & FF FLANGES</p> 	<p>HN 208 A (HN 203)</p> 	<p>NFE 29203 NFE 29209 DIN 2632 TO 2638 ASME B16-5 ASME B16-47</p>
<p>TONGUE & GROOVE FLANGES</p> 	<p>HN 113 , HN 213 SP</p> 	<p>DIN 2512 DIN 2513 ASME B16-5 NFE 29203</p>
<p>RTJ FLANGES</p> 	<p>HLO 210</p> 	<p>ASME B16-5 NFE 29203</p>

REMINDER OF GASKET STANDARDIZATION

Gasket Standards																		Flange Standards		
Former standards	NF (France) DIN (German)		PN10 2632	PN16 2633		PN25 2634	PN40 2635		PN64 2636	PN68		PN100 2637		PN160 2638		PN250 2628	PN320 2629	PN400	NF(France) DIN (German)	
	NFE 29 900-3 (*)		ISO PN10	ISO PN16	ISO PN20	ISO PN25	ISO PN40	ISO PN50	•	•	ISO PN100	•	ISO PN150	•	ISO PN250	•	•	•	NFE 29-203 NFE 29-209	V.1989 V.1985
In effect	ASME B 16.20 (E.G. API 601)	V.2012			Class 150			Class 300		Class 400	Class 600		Class 900		Class 1500				ASME/ANSI B16.5 ASME B16.47 series A (MSS-SP 44)	V.2013 V.2011
	NF EN 12560-2	V.2013			Class 150			Class 300			Class 600		Class 900		Class 1500				NF EN 1759-1	V.2005
	NF EN 1514-2	V.2014	PN10	PN16			PN25	PN40		PN63			PN100		PN160				NF EN 1092-1	V.2013

(*) The dimensional equivalences for the external Ø of 503 and 503R gaskets, between US and ISO PN standards, depend on the bolting used (UNC or ISO). This point should be checked, particularly for DN < 50.

• Standard eliminated in NF E 29-900-3. The external Ø of gaskets under NF E 29-900-3 are given for ISO bolting.

CAUTION: do not confuse PN 100 from the old NF standards and standard NF EN 1514-2 with ISO PN 100 from standard NF E 29-900-3.

Note, "class" gaskets are require UNC bolting. The information provided in these tables may be modified based on changes to the standardization.

Necessary Information for the Study

HELICOFLEX® APPLICATION DATA SHEET

Company _____
 Contact _____
 Address _____
 End User _____
 Ref. _____

Tel _____
 Fax _____
 Email _____
 Date _____
 Installation location _____

EXPORT CONTROL (PLEASE PROVIDE ALL REQUIRED INFORMATION)

Country of Destination _____ Is export controlled (ITAR, EAR, NRC)? Yes No Export Classification _____

WORKING CONDITIONS (INFORMATION REQUESTED FOR ANY INQUIRY)

Seal Inner Diameter (mm) _____
 Working pressure (0 If Vacuum) (bar) _____
 Working temperature (°C) _____
 What is the seal type? Shaped Circular
 Pressure: Inside Outside Axial

New Assembly Yes No
 Medium _____
 Are Modifications Possible? Yes No
 State: Gas Liquid Vacuum

CONDITIONS (INFORMATIONS REQUESTED FOR ANY INQUIRY)

Dimensions in millimeter. Please provide drawing.

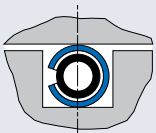

Grooved flange
HN100/200

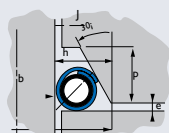

3 faces assembly
HN140/240



Vacuum
HNV100/200

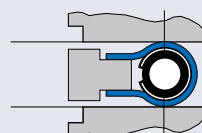

Flat or raised faces
HN108/208

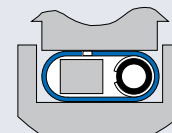

Tongue & groove
HN113/213

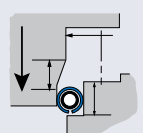

Radial
HN110/210

FEATURE (PLEASE PROVIDE DRAWING)

Bolting _____
 Type: _____
 Diameter: _____
 Bolts number: _____
 Material: _____

Standard Assembly:
 Standard: _____
 DN ; " : _____
 PN ; Class: _____

Special Assembly:
 Flange faces: _____
 Dimensions: _____
 Flange 1 material: _____
 Flange 2 material: _____

Sealing Face:
 Type (groove, tongue, & groove, flat): _____
 Dimensions: _____

Surface Finish:
 Type (turned, machined, other): _____
 Rugosity (Ra µm): _____

Other: _____

OTHERS

Process: _____
 Temperature Cycle: _____
 Pressure Cycles: _____
 Differential Dilatations: _____

Life time: _____

Leak rate Requested:
 Helium: _____
 Flow: _____
 Other: _____

Previous Solutions:
 Seal type, results: _____
 Solutions considered: _____

Quantity: _____ pces/year **COMMENTS:** _____

ISSUER: _____

DATE: _____

For more information on Technetics Group
world class sealing technology, visit
technetics.com

FRANCE

90, rue de la Roche du Geai
CS 52913
42029 Saint Etienne cedex 1 FRANCE
Phone: +33 (0) 4 77 43 51 00 Fax: +33 (0) 4 77 43 51 51

49 Avenue Charles de Gaulle
Z.I. Survaure
42607 Montbrison cedex FRANCE
Phone: +33 (0) 4 77 96 79 80